

Build the Bioelectrifier

Can you heal yourself and take a poke at the medical establishment at the same time?

Thomas M. Miller W8BYKN
314 South 9th Street
Richmond IN 47374

Back by popular demand, this article is reprinted—with a new addendum—from May 1996.

One of the first things a new amateur learns is that electricity and biology are not very compatible. A brush with the AC line can be a painful experience, and accidental contact with the high-voltage supply of a large transmitting tube can be fatal. Because of this early training, occasionally reinforced by an unpleasant accidental jolt, it might surprise some hams that tiny electrical currents can be beneficial to the human body.

For some time, doctors have known that passing a small current through a broken bone will cause it to heal faster. Damaged tendons and nerves also seem to respond to this treatment. Exactly why this works is not known, although a doctor once explained to me that it seemed to focus the body's attention on the area.

Recently, doctors at the Albert Einstein College of Medicine reported discovering that passing a current of

only 50 microamps through the blood can prevent certain viruses, notably the HIV virus, from replicating. The current became even more effective when the polarity was reversed several times a second. The implications are enormous.

Unfortunately, there has been very little interest in this phenomenon by the medical community. Those of us who read Wayne Green's editorials have become aware of a simple device which introduces a small electrical current through the legs by placing electrodes on the ankles. Since the arteries in the legs are large, and the blood has less electrical resistance than the surrounding tissue, this technique results in most of the current flowing through the blood. This is an ideal approach for amateur experimentation, since it is totally external, and the required voltage and current levels are so tiny as to pose no danger. I decided to design such a device, using a simple printed circuit board, and easily



Photo A. The Bioelectrifier with belt clip and ankle electrodes.

obtained parts, so that it could be duplicated by other amateurs.

At this point, let me state that I make no medical claims for this device. To paraphrase a famous Chief Medical Officer, I'm an engineer, not a doctor. Since very few doctors are electronics experts, there are many who would love to research the possibilities of this approach to eliminating viruses in the blood, but are unable to build the needed experimental device. They need your help.

So I present this circuit for those wishing to help doctors experiment in an unknown field, and also as an interesting study in design and construction.

Designing a Bioelectrifier

Before attempting to design any device, it's a good idea to make a list of goals. In this case, it's a simple list:

(1) The device should produce a current flow of 50 microamps from one ankle to the other. Experimentation has shown that this requires 30 to 35 volts.

(2) It must be capable of reversing the current flow several times per second. This rate should be adjustable.

(3) It must be all solid-state—no DPDT relays clacking away, eating up the batteries.

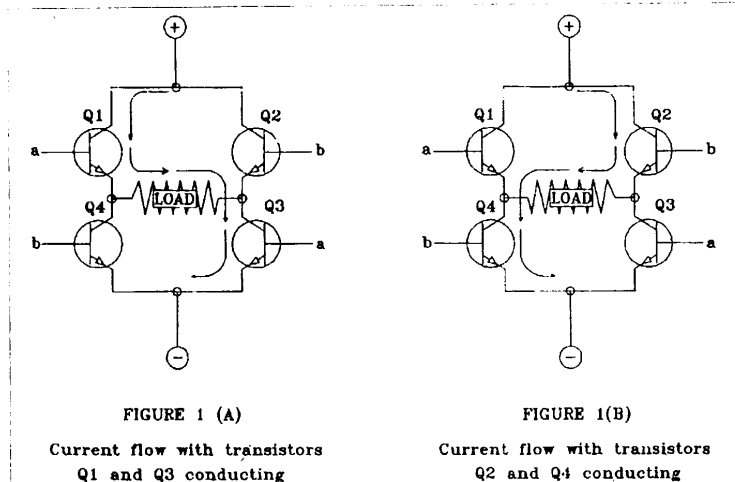

Fig. 1. Four transistors are used to reverse the current flow by being energized in pairs.

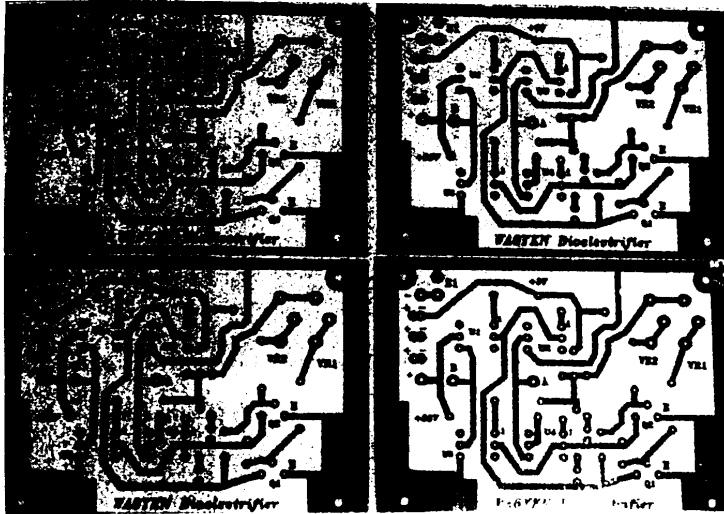

Photo B. Four circuit boards are etched on a single piece of copperclad and are cut apart after drilling.

(4) It must be small, light, and easy to carry. The ideal form would look like a pocket pager.

(5) It must have a low current drain for long life from small batteries.

(6) It must be as simple and inexpensive as possible, so that it may be easily reproduced.

This last goal is one of the most important in designing any device or circuit. It is, in fact, Occam's Razor, a corollary which states that when there are many ways to solve a problem, the best solution is the simplest one.

At first glance, it would be tempting to

use logic chips, or perhaps a 555 timer and a flip-flop to get a variable timebase in this direction leads to a regulated power supply, high current drain, and a complex circuit. Also, logic chips will not switch 35 volts without an additional driver stage. Remember rule number six... the simplest way!

Maybe we'd be better off starting from the other end. Reversing polarity requires the solid-state equivalent of the DPDT relay. As it turns out, there is just such a circuit commonly used to drive

and reverse DC motors. It uses four transistors in an "H" configuration, the load being in the center (see Fig. 1). When transistors 1 and 3 conduct, the current flows in one direction, while energizing transistors 2 and 4 reverses the flow. Most small switching transistors will stand up to our requirement of 35 volts at 50 microamps, but here we run into a new problem. For each direction, two transistors are in series, with the load in the middle. This creates a difficult bias arrangement to drive both transistor bases equally. Fortunately, there is a neat solution—the optocoupler. This invaluable device contains an LED and a phototransistor in one package. Energizing the LED produces light, which causes the phototransistor to conduct. No base voltage is required; therefore there are no bias requirements. Optocouplers are usually used to drive another device, but our requirements are so small that we can use them as output transistors.

The cheapest optoisolators cost less than a dollar and will withstand over 30 volts with current ratings in the hundreds of milliamps. For a few cents more, optocouplers are available that will withstand 80 volts or more.

With four optocouplers in the output of our device, all that remains is to alternately drive them in pairs. The simplest circuit to accomplish this is the multivibrator—nothing more than two general-purpose transistors, two resistors, and two capacitors. Voltage is not at all critical, and since we will be connecting batteries in series to get 35 volts, we can tap off at the 9 volt point to power the circuit. While we're at it, adding two more resistors and two tiny LEDs will give a visible indication of circuit operation and warn us when the battery goes dead.

Varying the frequency of a multivibrator requires that two resistors be varied together, no big deal. Two gang potentiometers are ideal for this. In fact, our design goals do not specify that an equal duty cycle is required, or even desired. Two trim pots will give independent adjustment of the two states if this is needed. A fixed resistor in series with each pot will establish a maximum frequency limit, preventing the circuit from dropping out of oscillation when the pot is adjusted all the way.

We now have the basis of a simple,

The Bioelectrifier

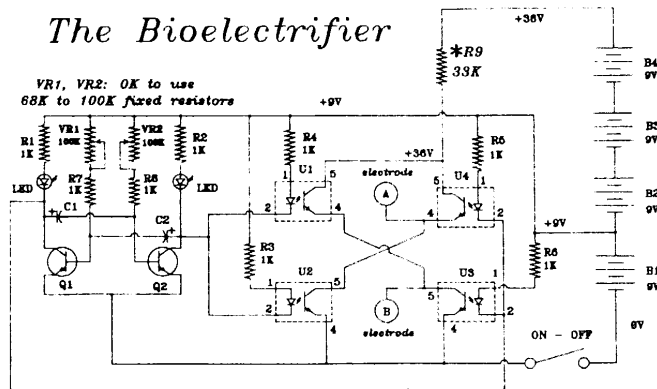

VR1, VR2: OK to use
68K to 100K fixed resistors

REVERSAL TIMES: C1 & C2	
2.2mfd	0.2 seconds
10mfd	1 second
33mfd	3 seconds

Q1, Q2: 2N2222 NPN TRANSISTORS
U1-U4: OPTOCOUPLER: ANY OF 4N25, 4N26, 4N27, 4N28 OR 4N38
parts available from
MOUSER ELECTRONICS: (800) 346-6873

Fig. 2. Schematic diagram of the Bioelectrifier.



Photo C. The Bioelectrifier – component side of the board.

practical design: four optocouplers, two transistors, one dual pot, two capacitors, two LEDs, and eight resistors, all of the same value! The schematic diagram is shown in Fig. 2. Of course, we will have to add a box, switch, and batteries, and some sort of electrodes. We also need a name. Since we are experimenting in bioelectrics, let's call it the Bioelectrifier!

The printed circuit board

When designing a printed circuit board for this type of project, a compromise must be made between size and ease of construction. The board should be single-sided with as few jumpers as possible, and there should be enough room for 1/4 watt resistors, in case the smaller 1/8 watt are not available. The final design is shown in Fig. 3.

In my work, I design and build a lot of prototype circuits, and I've settled on an easy technique for circuit board fabrication. I use a Computer Aided Design (CAD) program to create the actual pattern, and then use the computer to generate a mirror image. If the board is small, as in this case, I will then copy this mirrored pattern to get the maximum number of circuits from a standard positive pre-sensitized copperclad board. This mirrored array is shown in Fig. 4. After printing this pattern, I copy it with a standard copy machine and inspect the copy for places where the toner is less than pure black. These areas, if any, are touched up with a felt tip marker. When I've got a pattern that will give a good, pure black copy, I run two or three

W
M
an:
*Get
prac
appr
*Since
hans a
variety
menus
*This p
charact
your ov
copy b
Farnsw
can for
minute
Certi
by
Sour
Tech
S
The S
repeats
plus a r
batter
(8)

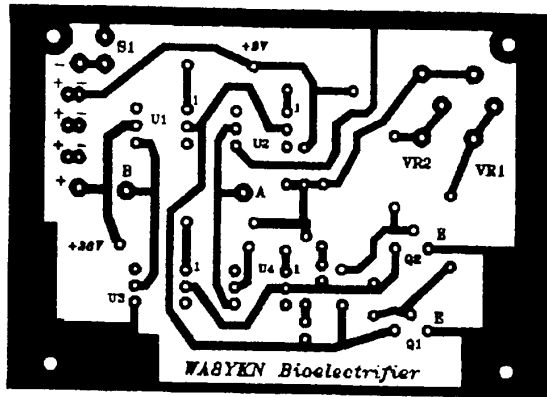

Fig. 3. The circuit board pattern, shown actual size.

copies to warm up the drum, then make a final copy on clear Mylar, sold in office supply stores for making overhead projector displays. It may be necessary to set the copy machine one step darker than normal, since machines tend to vary in how well they work with Mylar. This copy can be used as a positive for printing the circuit board.

Using a standard (4.5" by 6.5") presensitized board, place the Mylar sheet with the circuit board pattern *toner-side down* on top of the board. (The writing should be correct— not reversed!) Place a piece of glass over the Mylar to hold it in contact with the board, and expose it for three and a half to four minutes using an Ultra Violet sunlamp 12 inches above the board. Be sure to protect your eyes during the exposure!

After the board is exposed, dunk it in the developer until all the copper between the traces is shiny and clean; this usually takes around two minutes, but you really can't overdo it. Rinse the board with cold water, and it's ready to etch.

I etch my boards with ferric chloride solution in a tall, thin plastic tank that allows the board to stand up vertically. The use of an aquarium heater and air pump will cut the etching time in half. Do *not* get the etching solution on anything made of metal - it will corrode badly. It also stains everything, so wear rubber gloves and be careful!

After etching, clean the etch resist from the board, polish with steel wool, and drill the holes. The individual patterns can be cut from the board using a bandsaw, jigsaw, or even by hand with a hacksaw if that's all you have. You now have not one, but four circuit boards ready for construction.

Building the Bioelectrifier

Fig. 5 shows the parts layout for the Bioelectrifier. Be sure to install the optocouplers correctly. Also, the very small LEDs often do not have a flat spot to indicate the cathode, but instead have one lead shorter than the other. Check before cutting the leads! The *long* lead connects to the dropping resistor.

There are two ways that this circuit can be built. For experimentation, the device can be mounted in a larger box, potentiometers used to vary the frequency and current, and perhaps even a microammeter to monitor the current. However, I've discovered that it's not always wise to give a device with many controls to a non-technical person, especially if changing any of the adjustments would nullify the experiment. Also, we want a pocket-sized device, or one that can be clipped to the belt. Once the operating parameters are established, the resistance of the potentiometers can be measured and the pots replaced with fixed resistors (I used 68k). This makes a much smaller package possible, with only a single on/off switch and two tiny LEDs on the outside. I built one in a 2 7/16" by 5-1/16" plastic box (Radio Shack 270-233) and mounted the switch and LEDs in the end. Four 9 volt batteries would not fit in this box, but one 9 volt and two 12 volt "N" batteries will fit with no problem, and produce 33 volts. Radio Shack sells 12 volt alkaline "N" batteries in a package of two (23-154) and "N" battery holders (270-405).

I made a belt clip from a strip of steel banding material and glued it to the back. I also glued a two-pole terminal strip to the end of the box to connect the electrode leads, although a plug and jack would be fine. I used what I had on hand.

Electrodes for the prototype were simply strips of aluminum foil, folded to form two strips several layers thick, 2 inches wide and 12 inches long. Wrapped around each ankle, the foil was held in place by rolling the socks up over it. Later, a better electrode was made by gluing aluminum foil to strips of cloth backed vinyl.

upholstery material, with hook-and-loop fastener material glued to the ends.

In either case, connect two 36-inch lengths of hookup wire to the Bio-electrifier's output terminals, and solder a paper clip to the other end of each wire. Slip one paper clip over each electrode, clip the Bioelectrifier to the patient's belt, and your doctor is ready to go.

OK, it's done. Now what?

Even if your doctor doesn't know anyone with the HIV virus, there are many experiments he can try with the Bioelectrifier. If it works on the HIV virus, what about others, such as those responsible for herpes, Epstein-Barr, colds, and flu? Will a few minutes a day actually *prevent* colds and flu? What effect will different frequencies have? The long term benefits can only be determined by experimenting and recording the data.

It is interesting to note that all animal life on earth has evolved in the magnetic field of the planet. Blood, being mostly water and containing salts and iron, must generate a tiny voltage as it moves through this field. Is this voltage necessary for good health, and can it be disrupted by exposure to much more intense 60 Hz electromagnetic fields?

I've often wondered, as we think about manned missions to other planets, if we will one day discover that we cannot live for a great length of time without the Earth's magnetic field. So far, only a few people have ever left the planet, and only for a short time. These astronauts, however, have found that after a few days in space, the immune system starts to shut down! No one has yet found a good explanation for this. Perhaps a small application of bioelectrics is in order!

One interesting result reported by Wayne Green was that when his friend Beck used a similar device for two hours a day instead of the usual 20 minutes, just to see if there might be any harmful effects, he started losing weight! The weight loss continued until he reached his normal weight, then stopped. Since, as Wayne has repeatedly noted, many hams appear to be "eleven months pregnant," this could be the biggest thing since FM! Perhaps this device will open new fields of communication. Just adjust the frequency to match the 7 Hz resonant frequency of the Earth and tune your brainwaves to Dr. Jung's Universal Consciousness!

Ne
m
RF
ide
lin
AC
Kf
na
wh
po
col
-1C
an

Inc
del
ele
All
SA
Ma

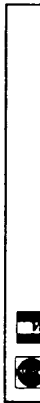

All kidding aside, there have been enough results from experiments to date to warrant serious study, and, as usual, mainstream science will continue to ignore it, while sucking up government funds for expensive and ineffective research. But breaking new ground is the amateur's forte. We have the technical skills and the manpower. Keep in mind that every new field is pioneered by amateurs—since the professionals do not yet exist!

One final caveat... *do not* build Bioelectrifiers and sell them as medical devices! This will surely bring unwanted attention from the wrong people. After all, these days even the U.S. Department of Health and Human Services has a S.W.A.T. team! So build it, work with a doctor to experiment, and make sure to keep careful records. Don't even give one away to someone who wants to try it but doesn't have the skills to build it, unless you have no qualms about opening yourself to almost unlimited liability. Remember, the FDA and several other government agencies have unlimited funds to persecute you, and they love nothing better than the slightest excuse to appear to be working. The last thing you need is to get the attention of the bureaucrats, who would probably protect the interests of the pharmaceutical cartels by

outlawing bioelectricity, requiring us all to wear grounding straps on our behinds.

ANSWERS TO FREQUENTLY-ASKED QUESTIONS [NEW]

The response to the Bioelectrifier has been incredible. It's been a year since the original article saw print, and I can still count on a stack of letters every week. This stack becomes a flood whenever Wayne guests on the Art Bell show. Since there are common threads to many of these letters, I thought I should address some of the most frequently asked questions.

Bare circuit boards for the Bioelectrifier are available from FAR Circuits, 18N640 Field Court, Dundee IL 60118. And no, the phone has NOT been disconnected... the Chicago suburbs were assigned a new area code. Fred's number is (847) 836-9148.

Unlike the Rife devices, this circuit achieves its effect with direct current. However, the polarity must be constantly reversed because the body tends to quickly "charge up" and the current flow drops off. The frequency does not seem to make much difference, and I've used rates from 20 Hz down to 0.2 Hz successfully. One fellow sent me a very long table of resistor-capacitor values

and wanted me to fill in the frequency for each combination! (Yes, he was a ham.) The time constant will vary slightly with the leakage of the transistors, but you can get very close by multiplying MEGOHMS by MICROFARADS to get time in SECONDS.

The original ankle cuffs lined with foil made a good "field expedient" electrode, but after a time, the foil becomes wrinkled, and the resulting hot-spots feel like tiny critters nibbling at your ankles. An alternative is to line the cuffs with 2 inch-wide heavy stainless-steel tape, available from any auto parts store, or by mail from J.C. Whitney. This material is heavy and polished, and doesn't wrinkle easily. It's also possible to take the advice of Dr. Hulda Clark and wrap a layer of saltwater-dampened paper towel between the metal surface and the skin. If the electrodes are working properly, you can't feel 100 microamps.

By far the best alternative is the disposable EKG electrode. These are "peel-and-stick" with a non-messy conductive jelly. These are so good that you can get two to three times the current flow and not feel a thing! They are available from your doctor or chiropractor, or you can order them through your pharmacist. EKG leads are

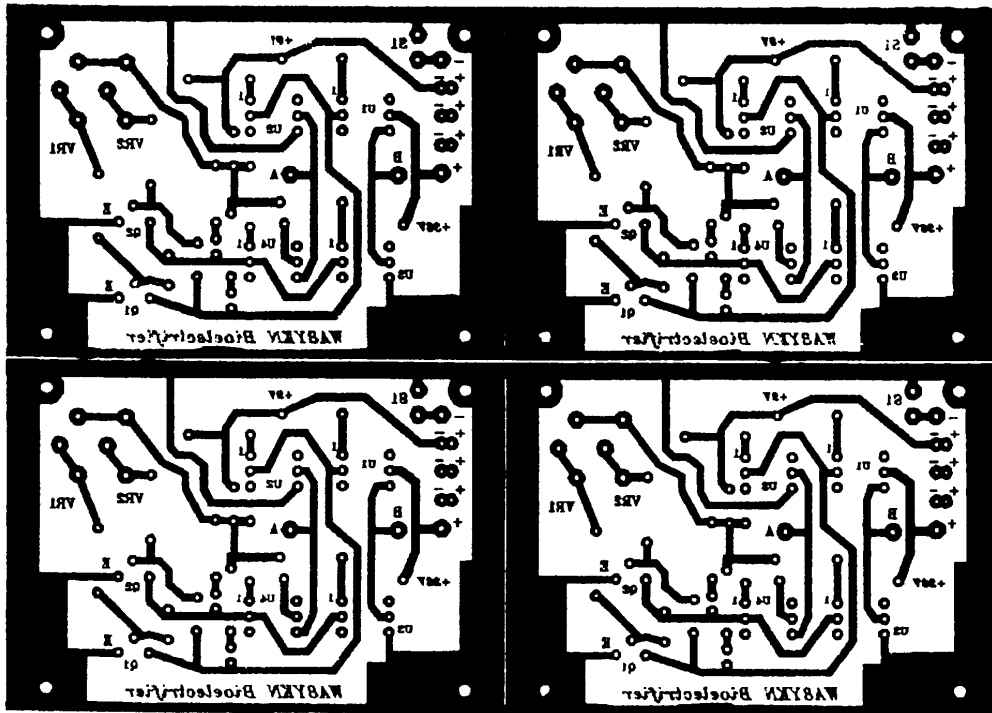

Fig. 4. Make your own "positive" by copying this mirrored pattern onto clear Mylar. Shown actual size.
18 73 Amateur Radio Today • May 1997

Bioelectrifier parts layout

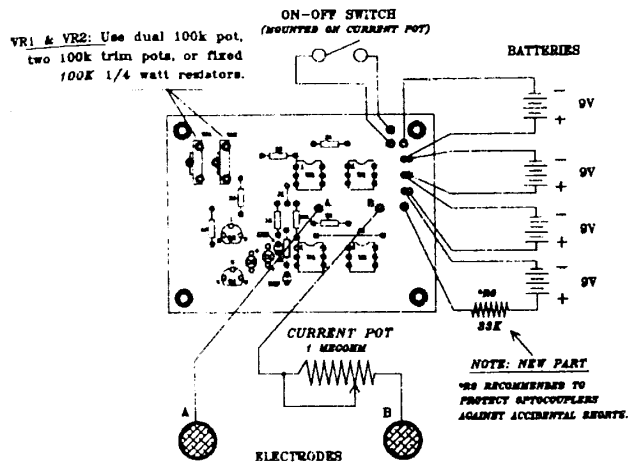

Fig. 5. Component side of the board, showing the component locations and connections.

made to snap onto the electrode, but small alligator clips work just fine.

If you write to me for information, please include a business-size SASE. My updates are now running three pages, so a post card won't do it.

While I can answer questions about

Bioelectrifier Parts List		
Part(s)	Mouser #	Radio Shack #
2 Transistors	330-PN2222	276-2009
4 Optocouplers	512-4N38	—
2 LEDs	351-3001	276-026
1 Dual Pot	31VA501	271-1732
2 4.7µF Capacitors	40XRL16V4.7	272-1024
8 1k Resistors	299-1k	271-1321
1 9V Snap	12BC310	270-405
2 "N" Holders	12BH510	270-405
1 Meg Pot	—	271-211
1 33k Resistor	—	271-1328

Box, switch, batteries, etc.

Materials for Circuit Boards

Materials for making your own printed circuit boards are available from Circuit Specialists: (800) 528-1417

Part	Number
Sensitized Boards	PP114
Developer	Posdev
Etchant	ER-3

the circuit, availability, and operation, remember that I'm an engineer, NOT a doctor. Please don't send me a letter detailing your health problems and asking for advice. That would put me in the position of practicing medicine without a license, and I can't do that! For information on what others have done and their results, get a copy of Wayne

Green's AIDS booklet. Also, Dr. Bob Beck lectures all over the country, leaving a trail of informative audio tapes and written reports in his wake. By the way, Robert C. Beck, D.Sc. and Robert O. Becker, M.D. are NOT the same person!

An important point brought up by Dr. Beck is that when using any bioelectric device, it's necessary to stay away from toxic drugs, alcohol and even herbs. An effect called ELECTROPORATION can increase the effect of these chemicals and cause toxic effects from a normally harmless dose. Dr. Beck also stresses the importance of drinking lots of pure water before, during and after using any bioelectric device.

I hope that readers will share the results of their experiments with the Bioelectrifier. You can write to me, or send me E-Mail at [thomil@infocom.com]. My Web site [http://www.infocom.com/~thomil/] is a good place to watch for new information, which I will post as it arrives.

—Thomas M. Miller WA8YKN

NOTE FROM W2NSD/I

I would make a lot more noise about this except for two things. Make that three. First, I'm not an MD, so the medical industry will probably have no interest in anything I have to offer. Second, efforts to try and bring down the cost of medical treatments could easily trigger an FDA attack and prison. Third, I need more people to call or write to say they used it with success. I've never had anyone write and say they had tried it and it didn't work, but I'd like more positive testimony.

